



**Le Technoparc**  
**17 rue C.E. JEANNERET**  
**78306 Poissy Cedex – France**  
**tel: +33 (0) 1 39 79 26 40**  
**fax : +33 (0) 1 39 79 91 22**  
**e-mail : ultraflux@ultraflux.fr**  
**web : www.ultraflux.com**



**Ultraflux NT 209B GB1**

Revision : 25/08/2008

**MiniSonic\_600 - B**  
**MiniSonic\_2000 - B**  
**Dual – pipe Versions**

## **PREAMBLE :**

Thank you for choosing Ultraflux to make your flow measurement.

We offer a full range of portable or fixed flowmeters backed by 30 years' expertise and experience using Ultrasonic techniques:

- ® Digisonic P or E & UF 801-P families, high features portable flow meters, with integral loggers and signal analysis functions.
- ® The UF322 & UF 8xx families of fixed flowmeters, applications include
  - L - Liquids,
  - G - Gas ,
  - MC : Multi-chord applications, Liquid and Gas flow measurement,
  - CO / RV : Open Channel and River Flow Measurement.
- ® The MiniSonic family with:
  - P – Portable Metering with also a two pipes or dual path version P-B 600/2000, single-channel fixed flowmeters,
  - 600-2 and 2000-2, for dual-chord flow metering,
  - 600-B and 2000-B, for dual-pipe flow measurement configurations,
  - Speed 1 & 2 are devices for open channel flow velocity measurements.

This manual is specifically concerned with an element from the family and has been drafted to guide you in the stages of installation and commissioning.

Other documents and tools are available on paper or in electronic format:

- ® A training manual concerning ultrasound measurement, reference NT 122
- ® A guide about the use of our software in the Windows environment Ref NT 204
- ® The PC software, specific to your application, Ref LS 600W \_version \*\*\* , with its delivered interconnection cable to a PC.
- ® The JBUS communication protocol with its address table NT 207

All our flowmeters work on the principle of transit time ultrasonics and can be associated with clamp-on or wetted probes depending on the application.

## **SUMMARY :**

- 1 – Typical Applications:
  - Installation on two different (and independent) pipes.
  - Installation on a same pipe or network: line balance.
- 2 – Composition of a measurement point.
  - Certification
  - Applicable standards
  - MiniSonic limitations
- 3 – Ergonomics and dimensions
  - Wall mounted industrial Version.
  - Ex d ATEX Version.
- 4 – Wiring diagram.
- 5 – Converter Assembling Instructions.
  - Mechanical installation
  - Electrical wiring.
- 6 – Probes installation.
- 7 – Setting and commissioning.
- 8 – Detailed Menu layout:
  - Measurement Display Menu
  - Calibration Allowed Menu
  - Pipe Settings Menu
  - Q Settings Menu – Flow and Fluid
  - Probe and Echo Menu.
  - General Parameters Menu
  - Zero / Auto-Zero Menu.
  - Current Output Menu
  - Factory Settings Menu.
  - Input / Output Test Menu
  - Echo Analysis Menu.
- 9 – Recommendations – Final checks and tests
- 10 - Investigations – Spare parts.
- 11 – Appendix

## 1 – TYPICAL APPLICATIONS

MiniSonic 600-B and 2000-B main purpose is to offer a performant ultrasonic flow measurement solution at a cheaper price compared to the use of two separated converters.

Their conception permits a smart share of the MiniSonic hardware and firmware ressources.

For instance, the end-user is free to set the two 4-20 mA outputs or the two relays as well.

Moreover, these two versions can calculate, display and transmit a QT flow value equal to the sum or the difference of the two flows that device measures on two independent pipes.

Another usual configuration is to install the two set of transducers on a same pipe and closed to each other to improve the measurement reliability or better at two different locations and do line balance or leak detection.

It is also possible to use first only channel Nr 1 and keep channel Nr 2 for a later use.

The following schematics are showing such typical applications:

### ® Installation on two different pipes:

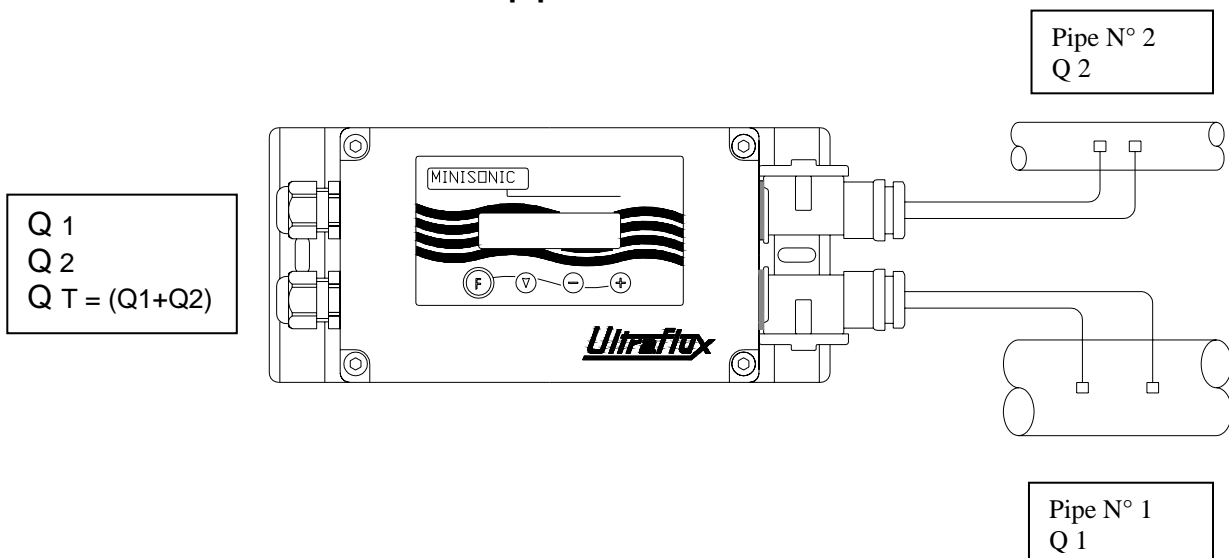

### ® Installation on a same network:

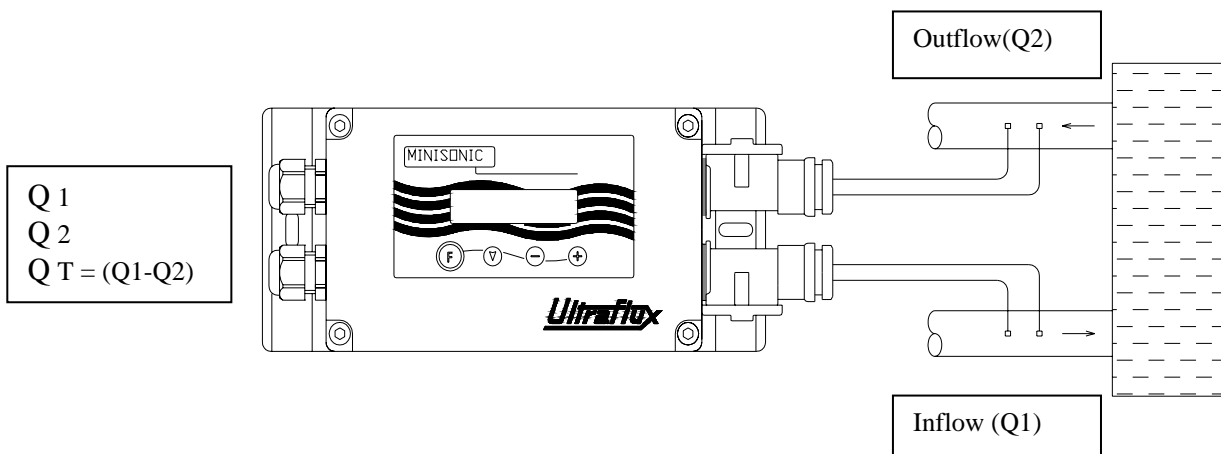

## **2 - COMPOSITION OF A MEASUREMENT POINT**

- The probes (x4) are arranged two per pipe.
- Integral or optional supports (SU)
- Coupling kits for external probes
- Probe / converter link cables
- The converter associated with its accessories (software, PC cable)
- If required, accessory modules: power supply transformer, Zener barriers

## **CERTIFICATIONS**

All equipment is CE certified.

ATEX certification for the relevant equipment and standards when this quality is required accepted and documented. All equipment will be labeled accordingly.

IP Rated as shown on each item.

*The IP 67 or 65 rating of a MiniSonic is only complied with if assembly is according to the manual and installations rules .*

## **APPLICABLE STANDARDS :**

- Concerning high voltage human safety risks: N/A – Only low voltage (< 60 V).
- Concerning EMC : EN 61000, EN 55022 et EN 50204
- Concerning tightness ( IP ) : EN 60529
- Concerning ATEX : Directive 94 / 4 / CE
  - + EN 60079-0: General rules.
  - + EN 60079-1 : Ex d enclosures.
  - + EN 60079-7 : Ex e protection for connections.
  - + EN 60079-18 : Ex mb x – protection by encapsulation.
  - + EN 60079-11 : Ex ia - Intrinsic safety
  - + EN 60079-25 to guide you for your I.S. systems
- Beware to take in account the energised lightings (from thunderstorms for instance) and to place adapted modules when this risk can exist.

## **MINISONIC LIMITATIONS :**

MiniSonic 600-B is designed for pipes from 10 up to 630 mm Outside Diameter .  
MiniSonic 2000-B is designed for pipes up to 3300 mm O.D.

The maximum length between transducers (**L**) is 1250 mm for version 600-B  
and 6600 mm for version 2000-B .

The maximum axial distances (**D**) are respectively 850 and 4400 mm.

### 3 - ERGONOMICS AND DIMENSIONS OF THE MINI 600 / 2000-B CONVERTERS

® **Wall-mounted industrial version ( IP 65 or 67 ):**

The resources for cabling the 4 cables leading to the probes are provided by the installation of double glands on a “Y” type with IP 65 protection level.

To preserve the MiniSonic index 67, an external extension box is necessary (optional supply). (Possibility also of a 316L St. St. enclosure with 4 glands for probes cables).

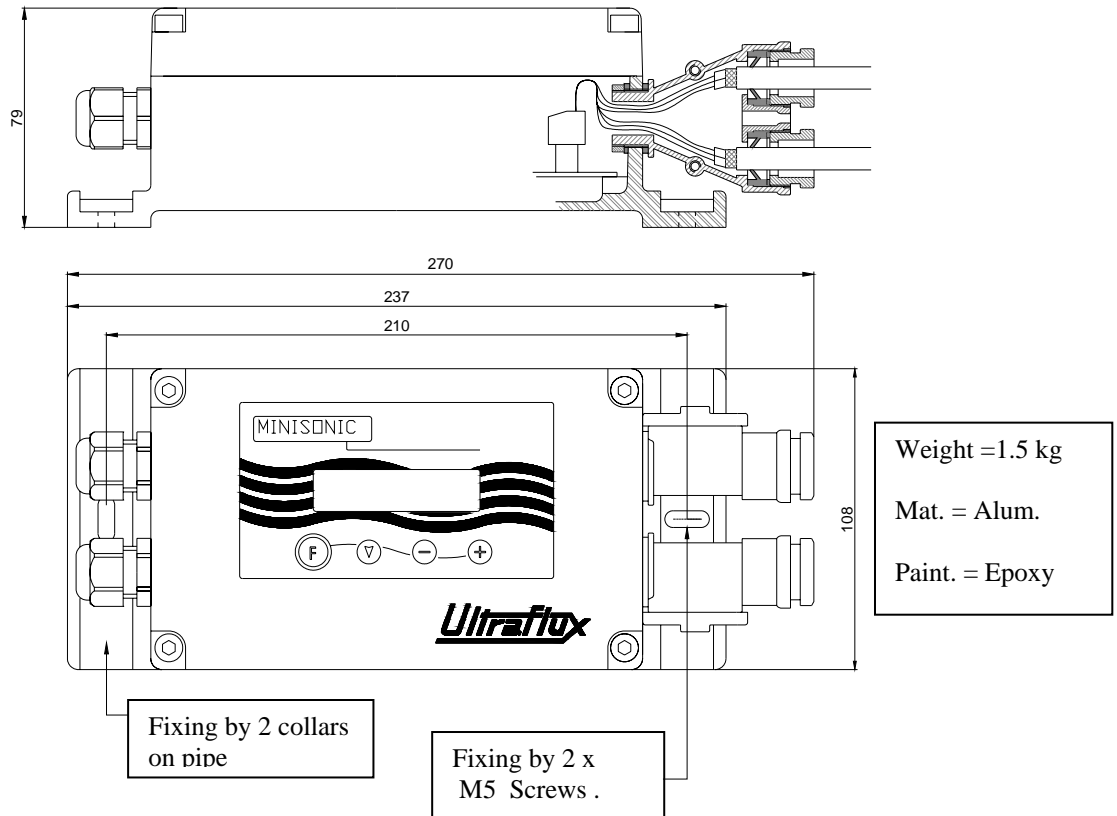

**F = Function      ▼ = Choice (menu ou parameter)      +/- = Modification**

*N.B.: To facilitate the wiring on the probe cable , it is advisable to remove the “Y” box .*

® **Version EXD ATEX (Ex d IIC T6 ) – IP 67 :**

**> See also the specific notice NT 219 B.**

- Each touch of the keypad has the same function as above.
- The two glands near the front are reserved for probe cables.
- These connections request the use of a double twin-ax from the MiniSonic to an Ex e or Ex d connection box from where start the 4 cables to the probes.
- To do the internal wiring on MiniSonic, it is necessary to remove the front of the MiniSonic board with its support. Remove the 3 screws which fix the front panel.
- The EMC is improved when cable screens or shields are earthed to the enclosure inside the glands.
- After the internal connections are finished, earth the MiniSonic board support with the green / yellow cable at the rear.
- The Enclosure itself must be earthed.

## 4 – WIRING DIAGRAM FOR MINISONIC 600-B & 2000-B : (Low Voltage Supply) (See also NT 128 if the GP 01 / 100 – 230 V AC // 24 V DC module is installed)

- Ⓜ The internal cables must be kept as short as possible. The cable connections must use the adjacent gland.
- Ⓜ For the Ex d version, the board is inverted (access is from underneath).
- Ⓜ The removable connectors are useful for wiring and maintenance purposes

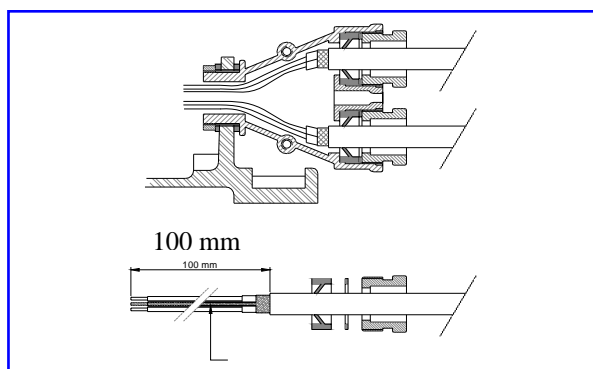
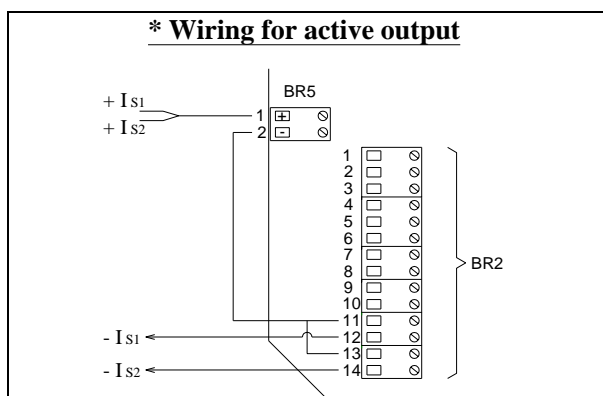
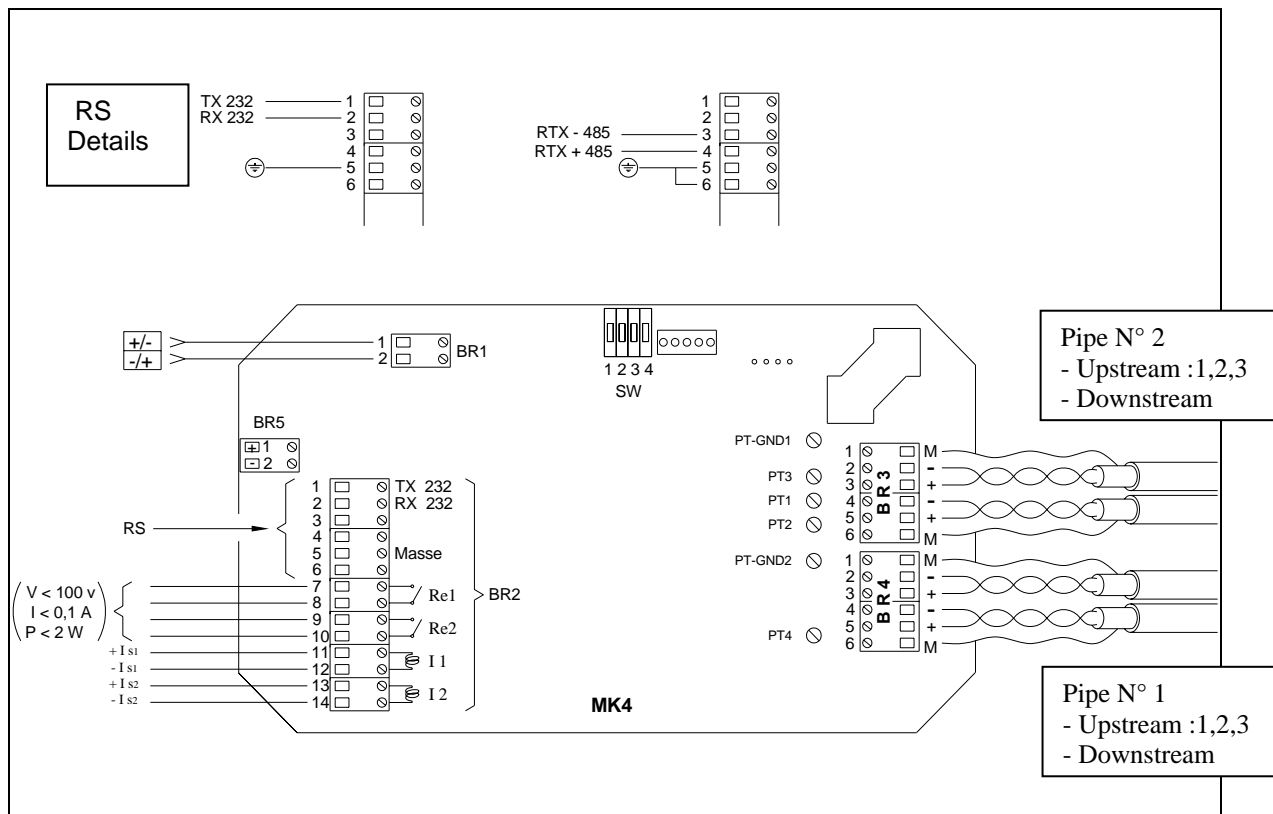

*Note: 1 & 2 on BR5 can be inverted to have (-) as the common*

Cables preparation (to probes)

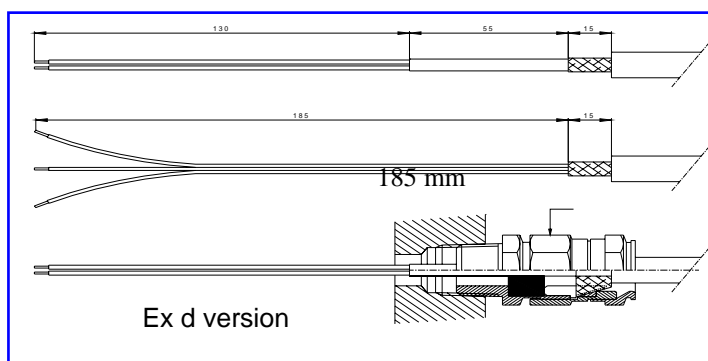

## 5 - CONVERTER ASSEMBLY

### ® Mechanical fittings

- ® Use a location that offers preferential conditions for easy access and vision.
- ® Avoid mounting on supports exposed to vibration.
- ® Avoid extreme weather conditions and direct exposure to the sun.
- ® Wall fitting is done by two M5 screws for industrial enclosures, or by using our support and fixing on a 2 " vertical tube with our Ex d version.

### ® Electrical connections: Refer to the diagram on the previous page.

#### ® Power supply: Connectors BR 1 – Use flexible cables with section 0.5 to 1.5 mm<sup>2</sup>.

- The recommended source is DC, 10 to 30 Volts (60 V on option): 12 / 24 (48).
- Any polarity will do. The required power is less than 2 Watt.  
The source may also be A.C. (9 to 18 Volts – 50/60 Hz) via a transformer.

#### ® RS 232 or 485 digital outputs: BR 2 A, terminals 1 to 6.

- Cable PC-DB9 uses RS 232 with Tx on 2, Rx on 3 and 0 Volt on 5.
- For a permanent link (logic controller, modem ... ):
  - . For RS 485: connect Rx – to terminal 3 and Tx + to terminal 4
  - . For RS 232: connect Tx to terminal 1 and Rx to terminal 2 with common to 5.
  - . No need of other connection to validate RS 232. Connect terminals 5 to 6 to validate RS 485.

#### ®- On/Off outputs - Relays (Static): BR 2B, terminals 7 to 10 – multi-pair cables

- Comply with the limits  $V < 100$  V;  $I < 0.1$  A;  $R_{ON} = 10$  Ohm.
- Each relay Re 1 (terminals 7 & 8) or Re 2 (terminals 9 & 10) will transmit the chosen status information in the "General Parameters" menu.

#### ® 4 – 20 mA analog outputs: BR 2B, terminals 11 to 14 – Multi-pair cables.

- These are independent outputs, **galvanically insulated** in respect to each other, but also with respect to the other MiniSonic circuits and by default are **passive** and need to be connected to a receiver supplying the power (30 V max.) to allow a load of more than 1 kOhm.
- Output No. 1 (terminals 11 & 12) and output No. 2 (13 & 14) will transmit magnitudes and ranges of variation as chosen in the "General Settings" menu: flow rate but also speed of sound, gain, etc....
- It is possible to carry out internal wiring to allow **active** outputs by associating the terminal block BR 5 (see diagram) already linked to power supply voltage connected to BR1, but with the drawback of losing part of the galvanic insulation.

*! With a 12 V DC or AC supply, R "loop" is limited to 150 or 200 Ohms.*

*Attention! If this R loop is too high for the supply, the current fall down to 4 mA*

#### ® Connection to probes: BR 4 (pipe1) & BR 3 (pipe 2).

- Use Twin-ax cables (ET 1217 & ET 1217A) specified by Ultraflux.
- In the industrial version, shield and conductors are separated in the "Y" compartment of the Y gland, while leaving a free length of 10 cm to terminal blocks.
- In the Ex d version, the shields are stopped and connected in the stuffing boxes and the conductors will be approximately 15 cm long up to the terminal blocks.

## 6- PROBES INSTALLATION – (General Procedures).

**Attention ! :** *The MiniSonic 600-B & 2000-B accept only one reference of transducer for both pipes, external (SE) or intrusive (SM). So a compromise is necessary for their size and frequency in relation with the pipes to be measured.*

- ® Unless specified and instructed otherwise in the order, refer to the probe data sheet of the model used.
- ® The installation of the probes in a conduit should allow for the best the straight lengths, particularly upstream, but also downstream, in order to benefit from a predictable and stabilized hydraulic profile. Provide upstream a minimum of 15 times the pipe diameter.



- ® Similarly, to avoid the nuisance of deposits or accumulation of gas, planes close to vertical ( $\pm 30^\circ$ ) will be avoided. A horizontal plane is a good choice excepted when the conduit is vertical.



- ® **For intrusive probes**, adjust the insertion then the alignment or orientation of the probes for the same pair ( $>$  parallel faces).

**Important! :** *once these adjustments finished , it is necessary to measure with accuracy the distances  $L_1$  et  $L_2$  between transducers face to face (pipes 1 & 2 ) and their projections  $D_1$  et  $D_2$  on flow axis and note these values on a “as built ” data sheet for further entering in instrument menu .*

*! The final accuracy depends on.*

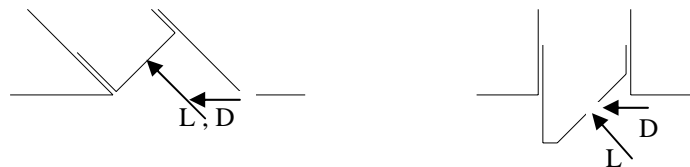

- ® For external probes, the freedom offered should not prompt the user to ignore the above rules

However, the choice of direct ( $\backslash$ ), reflex (V) or even (N or W) installation mode will depend on the decision regarding the conduit (state) and the fluids to be measured.

Therefore, we advise initially a provisional installation known as a validation installation (coupled with gel or grease) and final assembly (supports, solid coupling) once the conditions have been validated.

*Since the MiniSonic calculates for you the distance D.S 1&2 required between the probes, the setting up operations will, in theory, take place once the converter parameters have been set.*

Particular attention will be paid to cleaning the conduit at the probe location.

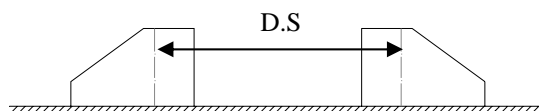

## **7 - COMMISSIONING AND PARAMETERING OF MINISONIC 600-B / 2000-B**

### **1. Once the cabling has been carried out and verified, power up the system:**

- ® The MiniSonic must display its delivered configuration screens:
  - Hardware version = MiniSonic 600-B or 2000-B\_P.C. Board MK4 M...
  - Firmware version = 18.10-01 (e.g. – make a note of the first figure)
  - Serial number = see if it is identical to the company nameplate
  - Technical information: parameterized probes

*Then it automatically switches to the measurement function (Q = ...)*

- ® Check the consistency of these messages with respect to your application.  
If the converter has been delivered pre-parameterized, startup can stop there.
- ® However, it is recommended you to check and, if necessary, to optimize the adjustments, taking into consideration the exact dimensions and, if possible, zero flow conditions (see the “Self-zero Adjustment” menu).

### **2. Parameter settings using the PC software** : *Use same version than Firmware*

- ® Refer to the manual supplied with the software (CD-ROM).
- ® The fields of the main values to be entered are listed below under Heading **8**.
- ® The software offers extended configuration possibilities.
- ® At the end of the manual, a printout of a typical file is given.

### **3. Parameter settings using the keyboard**

Successive pressing on the **F** key, or **F** then **+** or **-** gives access from the “Measurements Display” menu to the titles of the different menus :

- ® Access (Authorization) to Adjustments
- ® Pipe parameters
- ® Flow rate / Fluid parameters
- ® Probe parameters
- ® General parameters including Outlets
- ® Zero adjustment
- ® Tests
- ® Optionally : “Current outputs setting” and “Factory Adjustments”.

To enter the Menu, use the **▽** key in the same way as to move to the next field to be filled in .

To modify (text or values), use **-** or **+**

Exit from the menu is by the **F** key with return to the “Measurement Display” menu

*If there is no action on the keypad for 1 mn, the MiniSonic automatically returns to “Measurement Display” menu.*

*When inside a menu, the browser only scrolls forwards. When necessary, do a complete scroll.*

## 8 - DETAILED REVIEW OF MENUS – MiniSonic Versions 600-B and 2000-B

### 8 -1 : “ Measurement Display ” menu: ( with MiniSonic set with two pipes / channels )

Every time you return to this menu, MiniSonic displays  
chosen probes and interprobe distances D.S.( if S.E. )

Probe = SE xxxx  
D.S.1&2 = xxxx mm

Then Flow rate (or other choice as first screen)  
and associated messages .

QT = xxx.xx m3/h  
Seek Echo , Fault Q

▽ Gains 1 & 2 (mode and value)  
and channel 1&2 quality indicator.

Gain 1 (ESC) = xx dB  
I.Q.1 = 100 %

*If I.Q. is less than 33 %, the last  
Measurement cycle is rejected.*

Gain 2 (ESC) = xx dB  
I.Q.2 = 98 %

▽ Display of flow rate Q1 et Q2

Q1 = xxx.x m3/h  
Q2 = xxx.x m3/h

▽ Velocity of fluid and speed of sound  
on pipes or channels 1 & 2

V<sub>1</sub> = x.xxx m/s  
s.sound1 = xxxx.x m/s

V<sub>2</sub> = x.xxx m/s  
s.sound 2= xxxx.x m/s

▽ Physical measurements: time of flight T  
and difference dT on pipes 1 & 2

T<sub>1</sub> = xxx.x μs  
dT<sub>1</sub> = ns

T<sub>2</sub> = xxx.x μs  
dT<sub>2</sub> = ns

▽ Totalizers : Reset possible by  
simultaneously pressing + and -

t<sub>1</sub> = xxxx m<sup>3</sup>  
t<sub>2</sub> = xxxx m<sup>3</sup>

▽ Date and time  
*@ Change by PC + Software*

06/02/2003  
15 : 46 : 22

▽ Hydraulic Information  
Calculated KH and Reynolds number

Kh 1 & 2 = 1. 055  
Rey 1&2 = 3,1E5

▽ Return to menu header

## 8-2 : « Calibration Allowed » Menu :

® Access = press **F** once from the Measurement Display menu

® If the display is:  
Enter this code (1 to 65535)

**Calibration Allowed : 0  
Code ?**

® If the display does not request "Code?", there is none (code = 0)

® Press 

® Enter a code:

**Access Code = xxxx**

*! This code will become active after de-energizing.  
Remember to make a note of it. It will be required for any subsequent intervention.*

® In case of loss, contact Ultraflux giving the following information's; the serial number of your MiniSonic MK4\*/xx/xx/xxxx as it appears during energizing and the date or dates on which you want action to take place. An operation will be requested allowing a provisional code to be calculated.

® A second press on  will provide access to the existing Languages choice field.

## 8-3 : « Pipe Settings » menu :

® Access = Press twice on  or  once, then  and Enter by   
(Operations are common to all the menus).

 External diameters (mm)  
or pipes circumferences

**ext D 1 & 2 = xxxx.x  
ext C 1 & 2 = xxxx.x**

 Chosen pipe material  
from programmed list :

**Pipe 1 & 2 =  
STEEL... PVC ... OTHER**

If Other: Characterization of this material by its velocity or CM  
*This selection will resolve new or special cases and also optimize the parameters for composite pipes having several materials (steel or cast iron + cement*

 Total pipe thickness:

**Thickness 1 & 2= xx.x  
mm**

 If other:  
*N.B.: only one input.*

**CM = xxxx m/s**

## 8-4 : « Q Settings » menu ( Flow / Fluid )

® Following data are common to the two pipes.



Choice of Flow unit:  
( l/h ...tot ... m3/s );

**Q unit = m<sup>3</sup>/h**



Scale (graphics on PC only):  
*Outputs: see menu « General »*

**Qmax (unit)  
+/xxxxx.x**



Product (+ / -):

**Product =  
WATER / OTHER**

®If WATER: C = 1300 to 1600 m/s

®If OTHER:



Fluid Characteristic  
and speed of sound range :

**Co = xxxx m/s**

**Delta C = xxx m/s**



Hydraulic corrections (+ / -)  
*Prefer mode AUTO.*

**K Hydro = AUTO  
Or MANUAL**



Entry of Coefficient KH or data to do  
its calculation :

® If MANUAL: entry of coefficient  
depending on profile : Laminar = 1.333  
or Turbulent = 1.02 to 1.08

**K Hydro = 1.xxx**



® If AUTO: entry of parameters:  
Fluid viscosity:

**Viscosity (cst)  
x.x**



Pipe roughness:

**Roughness ( m m )  
xx.xx**

As well as the critical Turbulent /  
Laminar flow transition:



Critical Reynolds Number (Rey C)

**ReyC = 2800**



Transition range (LBR):













**LBR = 3**

*(Recommended values)*

**8-5 : « Probe / Echo parameter settings » menu :**

|   |   |
|---|---|
| <p>▽ For two pipes:</p>   | <p><b>Nb. Of Chords<br/>2</b></p>                     |
| <p>▽ Choice of probe:<br/><i>Same choice for the 2 pipes</i></p>  | <p><b>Probe = SE xxxx<br/>(or SM ou SP. A/B)</b></p>  |
| <p>▽ ® if SE (External probes)<br/>I = single traverse<br/>V = reflex mode<br/>N , W = 3 or 4 paths</p>   | <p><b>Probe mounting = V<br/>( or I , N , W )</b></p> |
| <p>▽ ® If SM (wetted internal probes)<br/><i>See parameters L , D 1 &amp; 2</i></p>                       | <p><b>Gain 1 = ESC</b></p>                            |
| <p>▽ Management of amplification gains:<br/><i>ESC Mode recommended.<br/>(ESC=Echo Shape Control)</i></p> | <p><b>Gain 2 = ESC</b></p>                            |
| <p>Otherwise :</p>  | <p><b>Gains 1 &amp; 2 = xx dB</b></p>                 |
| <p>® If MANUAL:<br/>(gain adjustment.)</p>  | <p><b>Margin. 1 &amp; 2 = xx dB</b></p>               |
| <p>® If AUTO: Margin<br/>(Over-amplification compared to<br/>critical gain Go. )</p>                      | <p><b>Margin. 1 &amp; 2 = xx dB</b></p>               |
| <p>▽ If SM choice: position of probes depending<br/>on geometrical measurements .</p>                     | <p><b>Length 1 &amp; 2 = xxx.x<br/>mm</b></p>         |
| <p>® as distance between probes , face<br/>to face , per chord (L)</p>                                    | <p><b>Length 1 &amp; 2 = xxx.x<br/>mm</b></p>         |
| <p>▽ ® as projected distance onto flow axis<br/>(Part of L concerned with the flow)</p>                   | <p><b>Ax. D 1 &amp; 2 = xxx.x mm</b></p>              |

**8-6 : « General Settings » menu**

|   |  |
|---|--|
|  <p>Setting of LCD back-lighting<br/><i>(Depending on MiniSonic version)</i></p>                               | <p><b>Back Light</b><br/><b>ON / OFF / TIMED</b></p>                           |
|  <p>Filtering rate of measurements<br/><i>Time = N* 0.5 (0.5 s per cycle)</i></p>                              | <p><b>Filter = **</b></p>  |
|  <p>Last accepted measure (IQ &gt; 33%)<br/>memorising time :<br/><i>(mode ESC : enter Mem.= &gt; 20 )</i></p> | <p><b>Mémoire (s)= **</b></p>  |
|  <p>Setting of Totalizers 1 &amp; 2<br/>® depending on flow direction:</p>                                     | <p><b>+ , - , +/-</b></p>  |
|  <p>® depending on flow QT , Q1 or Q2 :</p>  | <p><b>Totalizer 1</b><br/><b>Q 2</b></p>                                       |
|  <p>® depending on weight or unit :<br/>(from 1 cl to 100 m3 )</p>   | <p><b>Pulse weight =</b><br/><b>1 m3</b></p>                                   |
|  <p>Setting of Relays 1 &amp; 2<br/>® by assignment :</p>   | <p><b>Closed/Open /TOT.1 ou 2 /</b><br/><b>Fault Q/ Dir.Q/ Threshold Q</b></p> |
|  <p>® If copy of TOT 1 or TOT 2 :<br/><i>= relay closing time &gt; F maxi</i></p>                            | <p><b>Pulse width ( ms )</b></p>   |
|  <p>®If Threshold: enter value for flows<br/>Q1, Q2 or QT</p>  | <p><b>Threshold R2 (unit)</b><br/><b>Value</b></p>                             |
|  <p>Reset to Zero of TOT. t1 &amp; t2<br/><i>This function may be prohibited</i></p>                         | <p><b>Reset t1 &amp; t2</b><br/><b>NO / YES</b></p>                            |
|  <p>Parameter settings of two outputs<br/>4-20 mA, SA 1 &amp; SA 2<br/>® by assignment :</p>                 | <p><b>SA 1/ SA2 Type</b><br/><b>Q1 , Q2 , QT , V , C , GAIN 1&amp;2</b></p>    |
|  <p>® by range ( depending on unit )</p>   | <p><b>4mA SA 1 &amp; SA 2</b><br/><b>+ / - xxxx.x</b></p>                      |
|   | <p><b>20 mA SA 1 &amp; SA 2</b><br/><b>+ / - xxxx.x</b></p>                    |
|  <p>RS 232 ou 485 Communication<br/>JBus slave No and Baud Rate :</p>  | <p><b>N. JBUS = 1</b><br/><b>BAUD = 9600</b></p>                               |

**8-7 : « Zero / Autozero Settings » menu**

|   |  |
|---|--|
| <p>▽ Status display:</p> <p>Modification by + / - :</p> <p>Ⓡ no compensation ( reset ) :</p> <p>Ⓡ performs the zero under actual conditions ( flow must be null )</p> <p>Exit by <b>F</b></p> | <div style="border: 1px solid blue; background-color: #e0ffe0; padding: 5px; width: fit-content;">Delta To 1 &amp; 2 ( ns )<br/>= xx.xx ( ns )</div> <div style="border: 1px solid blue; background-color: #e0ffe0; padding: 5px; width: fit-content; margin-top: 10px;">RST Delta To 1 &amp; 2</div> <div style="border: 1px solid blue; background-color: #e0ffe0; padding: 5px; width: fit-content; margin-top: 10px;">Autozero 1 &amp; 2</div> |
|---|--|

*! Caution = to carry out Self-zeroing, the flow rate must be absolutely zero while the display indicates « \* dTo 1 or dTo 2 \* » .*

**8-8 : « Output Current Settings » menu** ( normally reserved to Ultraflux )

It permits adjustment of coefficients to convert min / max range to 4 / 20mA

4 mA ( 1 & 2 ) = xxxx

*! Caution !: use an a approved instrument to measure current (in mA, resolution <0.01).*

20mA ( 1 & 2 ) = xxxx

**8-9 : « Factory Settings » menu** ( normally reserved to Ultraflux )

It permits to adjust a coefficient which optimises the compensation with clamp on probes ( value 0.6 to1.6)

Correction S.E. = 1.0

*Another parameter named “ Delta T band ” permits to set a compromise between filtering an response time for some difficult applications: please contact Ultraflux.*

**8-10 : « I / O Test » menu** : simulation on outputs and relays .

|   |   |   |
|---|---|---|
| <p>● (Action by + / - )</p> <p>▽ Simulation of status on Re 1 or Re 2: (Action by + / - )</p> | <p>Sim</p> <div style="border: 1px solid blue; background-color: #e0ffe0; padding: 5px; width: fit-content;">Current 1 &amp; 2 = xx.xx<br/>mA</div> <div style="border: 1px solid blue; background-color: #e0ffe0; padding: 5px; width: fit-content; margin-top: 10px;">Relay 1 &amp; 2 =<br/>Open / Closed</div> | ▽ |
|---|---|---|

**8-11 : « Echo Display » menu**

|                                  |   |
|----------------------------------|---|
| <p>▽ It put multiplexing off</p> | <div style="border: 1px solid blue; background-color: #e0ffe0; padding: 5px; width: fit-content;">Chord 1 &amp; 2</div> |
|----------------------------------|---|

*This menu helps to observe echoes pipe by pipe.*

## **RECOMMENDATIONS**

Each application has its priorities. Accordingly, the MiniSonic is particularly flexible and can be adapted to extreme situations, meaning that many applications are possible.

Each value or text field is filled in by Ultraflux before the final tests and delivery.

Nevertheless, it is advisable to verify them by running through the various menus, comparing them with files given at the time of order, or with your instructions or particular choices.

More particularly, geometrical descriptions specific to the site and the choice of scale are the responsibility of the end user.

During a run-through of the various menus, it is advisable to fill in the "Probes / Echoes" menu first, followed by those related to the Pipe and the Flow Rate / Fluid (Q) to obtain a measurement to be transmitted according to the instructions entered into the "General" menu

## **FINAL CHECKS AND TESTS**

Once installation, connections and parameters have been set up, several possible situations may arise:

Case 1 – The measurement displayed and transmitted meets your expectations.

Case 2 – The measurement operates but may lack accuracy or is unstable.

Case 3 – The measurement is not reliable or the MiniSonic is displaying a Fault.

® **Case 1** : Although everything appears to be OK ( Flow Rate = OK ), check the other values:

- The echo or gain level compared to typical values.
  - For external probes, a gain exceeding 50/60 dB reveals certain difficulties such as the wrong choice of probes, incomplete installation or coupling, rusted pipe , absorbent fluid ...
  - For intrusive probes, the gain level is usually low (excepted for gas)

*// The ESC mode can decide a high gain margin. Take in account it in your diagnosis.*

- The quality index Q.I. is normally close to 100.
  - By default, it indicates several perturbations = electrical interference, passage of bubbles, highly charged fluid ...

*// In this case, in-depth investigation is advisable (oscilloscope).*

- The displayed speed of sound should be close to that expected. It is an index of good control of the geometry or application.

- If the flow rate can be interrupted, check the Zero

*// If necessary, carry out adjustment using the Auto-Zero menu.*

*// By PC and software, it is possible to set the measurement to Zero at very low flow (cut-off = % of Q max.).*

® **Case 2** : In addition to the points mentioned above, the possible causes are:

- Poor control of the installed dimensions, or of the product characterisation or of the Zero point :  
*∏ Correct and reanalyse*
- An installation constructed with poor hydraulic conditions :  
*∏ If possible, change the location (or the probes and their spoolpiece) if possible.*  
*∏ Otherwise, it is possible to choose  $K_{Hydro} = Manual$  and adjust this coefficient to obtain the expected flow rate reading . This coefficient will act on Q1 & Q2 results.*  
*∏ With insertion probes, it is possible to play on Axial D 1 or 2 separately.*
- The range of speed of sound to be measured is too wide for the chosen setup :  
*∏ With S.E. probes, a direct mode ( / ) may be preferable to a reflex mode ( V )*  
*∏ Have you correctly set Co and Delta C range?*
- An unstable fluid causing the ESC mode to restart too often:  
*∏ try the AUTO mode with a reduced margin ( ~ 12 dB)*
- The expected measurement requires greater precision :  
The MiniSonic allows the input of a “Linearization” correction law but it will be active for the two pipes (Otherwise, the solution is to use two separated MiniSonic) .  
*∏ Plot the error curve and use the software to enter the complementary law (Factory Adjustments Menu).*
- The Delta t offered by the measurement conditions (Diameter, Flow Rate, Assembly, Choice of probes) is too low to claim any measurement accuracy.  
*∏ Is it possible to revise these choices?*
- The measurement conditions reveal poor control of transitions from turbulent to laminar configurations:  
*∏ Revise the declared Reynolds Critical and range (LBR) values).*

® **Case 3** : The MiniSonic does not operate:

- There is no display or measurement transmission ( 4-20 mA ) .  
*∏ Is the MiniSonic powered up? Check with a voltmeter.*  
*∏ Has it failed? If yes, the only solution is to call in our after-sales service.*
- If the MiniSonic displays INIT constantly, attempt a power cutoff, then re-energize.  
*∏ If the fault persists, contact Ultraflux (Problem with the microprocessor).*  
*∏ If the fault disappears, it may come back and could be due to excessively high impedance in the supply source.*
- If the MiniSonic displays “Flow Rate Fault”, this message does not mean that the MiniSonic has failed, but that the ultrasound signals have not reached the expected level or are outside the window [Co +/- Delta C]. There are several possibilities :  
*∏ Pipe is empty?*  
*∏ Physical problem from site: Two-phase, highly charged or too viscous fluid?*  
*∏ Is pipe too old, which does not transmit ultrasonic signals?*  
*∏ Unsuitable installation mode = try Direct mode ( \ ) or other sensors.*  
*∏ Incorrect sensor installation (orientation, coupling ... ) .*

- If the problems are encountered only on one channel, it is easy to swap both channels and see if the issue is with the application or the MiniSonic.

## **10 - INVESTIGATIONS :**

If there is a difficulty or a problem, logical analysis can be assisted by the implementation of expert apparatus:

- Either an oscilloscope: the MiniSonic has test points for the purpose:

From low to high referring to wiring diagram § 4:

PT 4 = Echo – Alternating signal, peak to peak 4 Volt (-0.65 V negative threshold).

PT 0 = 0 Volt – Ground

PT 2 = Synchro –Positive edge 0 to 5 Volt

PT 1 = Selection windows .Echo must be inside.

PT 3 = Emission < > Reception transit time.

PT 0 = 0 Volt.

- Or a MiniSonic P or DigiSonic E / P portable flowmeter
- Or measuring instruments for dimensional or alignment measurements

## **SPARE PARTS :**

Ultraflux offers possibilities of purchasing spare cards or, as long as acceptance is granted, the standard replacement of equipment in the event of failure.

*// Contact the Ultraflux commercial services or the regional dealer.*

## 11 – APPENDIX

### Calibration file example with a MiniSonic 2000-B on a flow spool with clamp-on probes SE

Settings - U:\...iers Type\DualPipe Type Eng-01.eta (12/01/2004 - 11:21:05)

#### General

N. JBus = 1      Filter = 5 Cycle      1st screen =            QT  
                  Memory = 30 Cycle      Back light =            Timed  
  Line 1 =    ULTRAFLUX  
  Line 2 =    FIT\_01/02  
  Firmware =        16-

#### Probe

Number of chords =        2  
Probe =            SE1515-I  
Probe mounting =        V  
Stop meas. on = Zero Crossing  
US Impulse =            1

#### Pipe 1

Polarity = Normal  
Type of Gain = E.S.C.  
Margin =    15 dB  
Delta T0 1 = -0.40 ns

#### Pipe 2

Polarity = Reverse  
Type of Gain = E.S.C.  
Margin =    20 dB  
Delta T0 2 =    0.60 ns

#### Pipe - Product

##### Pipe 1

Ext. Diameter = 412.0 mm  
Material = Steel  
Thickness =    6.3 mm

##### Pipe 2

Ext. Diameter = 216.0 mm  
Material = Pvc  
Thickness =    8.0 mm

Product =    Other  
C0 =        1380 m/s  
Delta C =    300 m/s  
KH Type = Automatic  
Viscosity =    2.0 cSt  
Roughness =    0.10 mm  
Critical Reynolds = 2800  
L.B.R. =        3

#### Flow

Q Unit =    m3/h  
Max Q = 1000.0  
Cut OFF Q =    2 %

#### QT Calcul

QT = +1 x Q1 +1 x Q2

##### Totalizer 1

Direction = +  
Type = Q1  
Pulse weight = 100

##### Totalizer 2

Direction = +  
Type = Q2

##### Relay 1

Type = Fault QT  
Direction = Normal

##### Relay 2

Type = Threshold Q2  
Threshold =        50.0 m3/h  
Direction =        Reverse

##### Analog Output 1

Type = Q1  
4 mA = 0.0  
20 mA = 800.0

##### Analog Output 2

Type = Q2  
4 mA = 0.0  
20 mA = 200.0